

If the magnetic channel is too loud

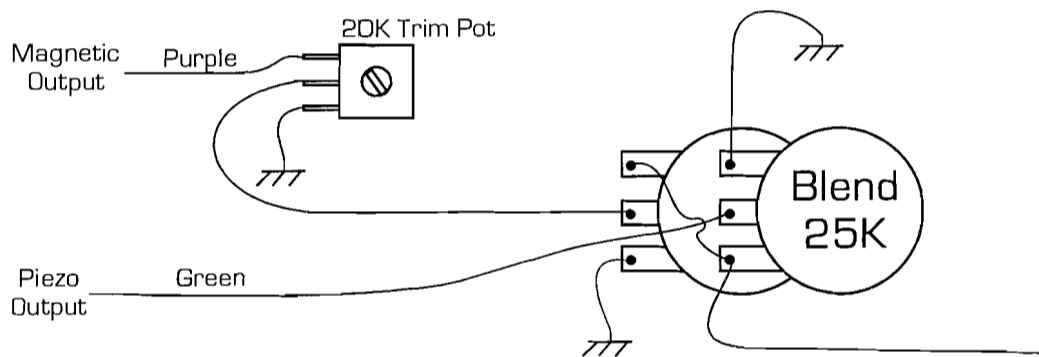

If the piezo channel is too loud

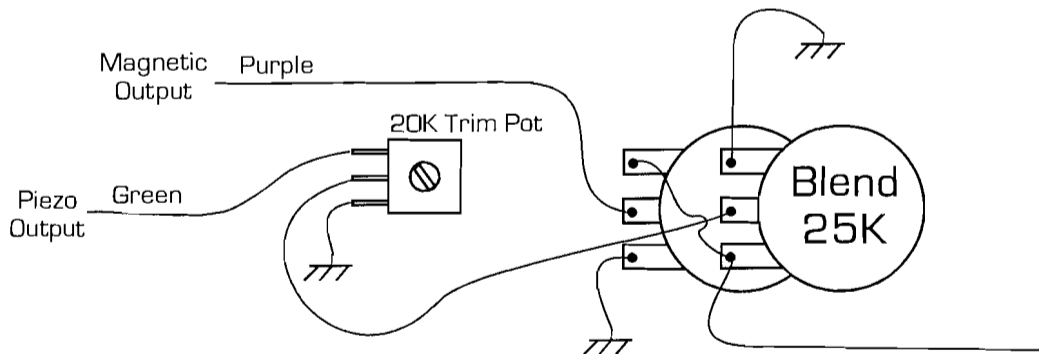

2 Magnetic Pickups & 1 Piezo Pickup with MPB2 & NTMB

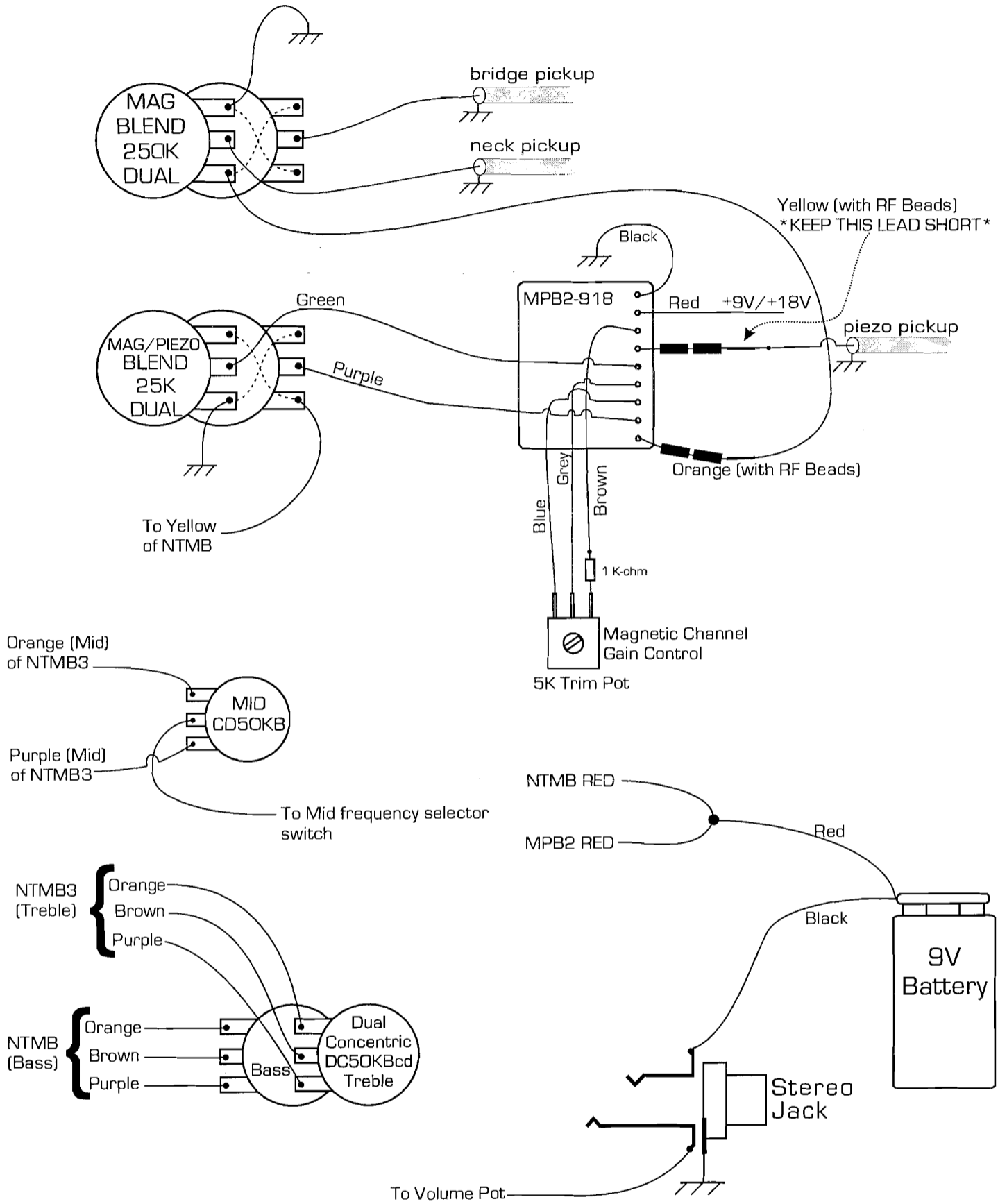

NEW Alpha (a) OR Noble (S) BLEND POTENTIOMETER WIRING

both of these new potentiometers have "silver" colored solderable plating
 both brands have C-A tapers (C=left hand audio - A=right hand audio)
 wiring is the same for 25 K-ohm and 250 K-ohm pots.

Alpha (a) bushing: 8mm

Noble (S) bushing: 3/8"

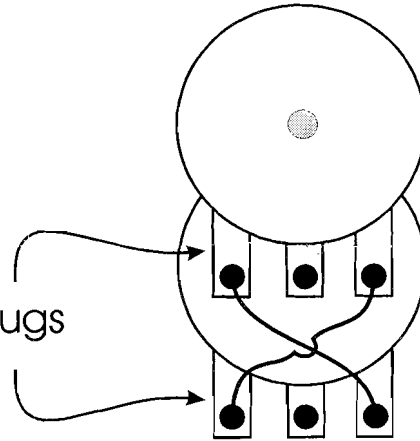
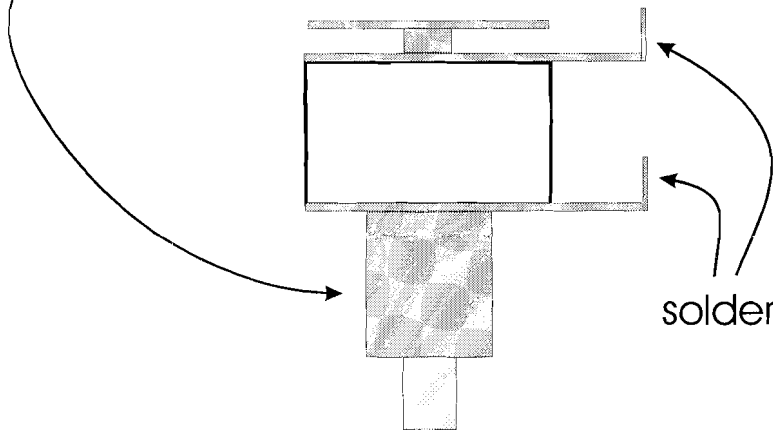

Blend pot wiring viewed from the inside
 of the control cavity (pot. shaft down)

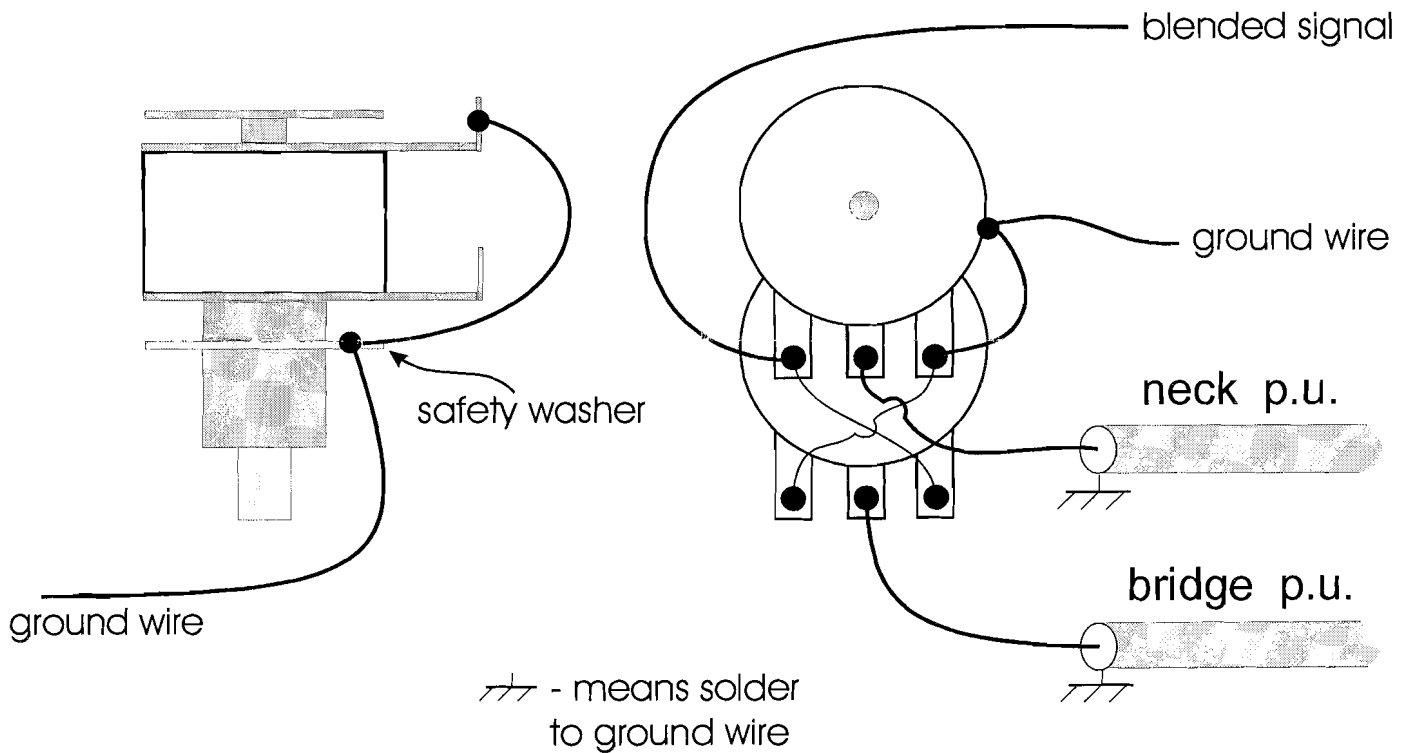

**DO NOT OVERHEAT WHEN SOLDERING GROUND WIRES
 OR ANYTHING ELSE TO THE SIDE OF THESE BLEND POTS**