



0230-0374rA

PO BOX 4394  
SANTA ROSA, CA  
95402 USA

P (707) 525-9941  
F (707) 575-7046  
EMGPICKUPS.COM

**METALWORKS**

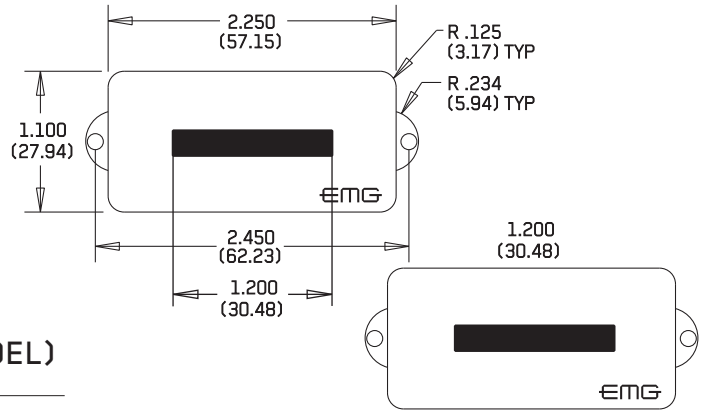

**INSTALLATION INFORMATION**  
EMG MODELS: LC-PA (LES CLAYPOOL MODEL)

**SPECIFICATIONS:**

Logo Color  
Magnet Type  
Resonant Frequency (KHz)  
Output Voltage (Finger, Thumb)  
Output Voltage (Thump)  
Output Noise (60 Hz)  
Output Impedance (Kohm)  
Current @9V (Microamps)  
Battery Life (Hours)  
Maximum Supply (Volts DC)

**MODEL:**

LC-PA  
Gold  
Alnico 5  
2.61  
2.00  
8.0  
-101  
3  
380  
1000  
27

**NOTE:** EMG Metal Works Pickups may be direct mounted with either short or long adjustment screws, depending on what works best for your instrument.

See Diagram #9 on page 4 for instructions on using the included mounting standoffs with long screws.

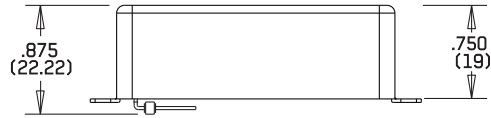

**INSTALLATION NOTES:**

All EMG Active Pickups are compatible with each other. EMG Accessories, the VLPF, EXG, SPC or RPC Controls can be added to any EMG system without requiring an extra battery. DO NOT reconnect the bridge ground wire, as EMG Active Pickups do not require string grounding. Use the 25K Ohm controls that are included for best results. If your output jack is a long panel style you will need to solder a stereo jack, like the SwitchCraft 152B or similar. Adjust the pickup level to the strings, and experiment with a distance that works for you. Alternate wiring diagrams are available at: emgpickups.com.

**INCLUDED WITH EACH PICKUP:**

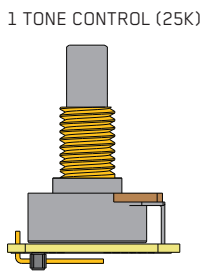
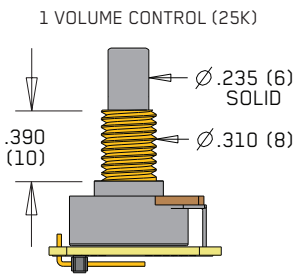

PICKUP CABLE 13.5" (34cm)



3 CONNECT CABLES 5.5" (14cm)



OUTPUT CABLE 6" (15cm)



BATTERY CABLE 7" (18cm)

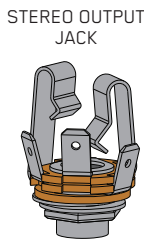
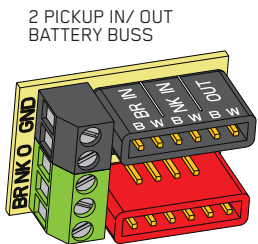
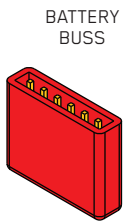

SHORT ADJUSTMENT SCREWS (4)



LONG ADJUSTMENT SCREWS (4)

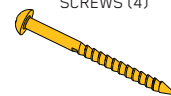

MOUNTING STANDOFFS (4)



**WARRANTY**

All EMG Pickups and accessories are warranted for a period of two years. This warranty does not cover failure due to improper installation, abuse or damage. If upon examination the pickup is determined to be defective, a replacement will be made. Warranty replacement products are covered by this same warranty. This warranty covers only those pickups and accessories sold by authorized EMG Dealers. This warranty is not transferable.

**Installation Instructions:**  
**EMG Models: LC-PA**

**General Notes:**

- Every attempt has been made to make this a solderless installation. There are some instances where this is not possible;
- 1) If your instrument uses a long panel output jack and you had passive pickups you will need a new stereo output jack (the Switchcraft 152B is recommended). Soldering to the new jack will be required, see page 4.
  - 2) Power Supply tips are on page 4. If your instrument has a battery holder, you are installing this pickup with an older EMG, or you want to supply your instrument with +18 Volts, see page 4 for tips to avoid soldering.

If you are installing only one pickup use the instructions on this page.  
 If you are installing two pickups go to page 3 and begin there.

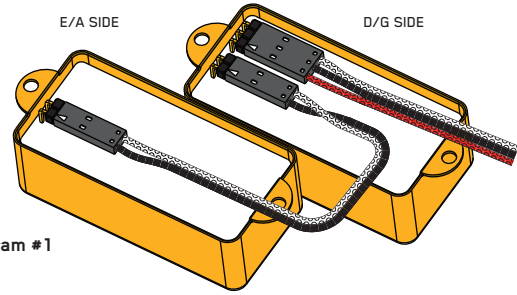

**Diagram #1**

**Installation (One Pickup Basses):**

- 1) Plug the pickup cable onto the EMG Pickup header as shown in Diagram #1 and route the cable to the control cavity. If the cable is too long, wind up the excess and keep it under the pickup if possible.

**Master Volume control only**

- 2) Refer to Diagram #2. Plug both the pickup cable and the output cable onto the volume control as shown, then go to step 4.

**Master Volume and Tone control**

- 3) Refer to Diagram #3. Plug the pickup cable onto the volume control as shown. Plug a connector cable from the volume control to the tone control. Plug the output cable onto the tone control as shown.
- 4) Connect the wires of the output cable to the output jack by pushing the connectors on as shown. WHITE wire to the TIP (T) contact, BLACK wire to the SLEEVE (S) contact, BLACK battery negative wire to the RING (R) contact.
- 5) Using the battery buss, insert the RED wire of the pickup, and the battery RED wire. Extra pins can be used for EMG Accessories.
- 6) Wrap the battery in a piece of insulating foam and place it securely in the control cavity.

We suggest that you plug in the instrument and test it before closing the control cavity.

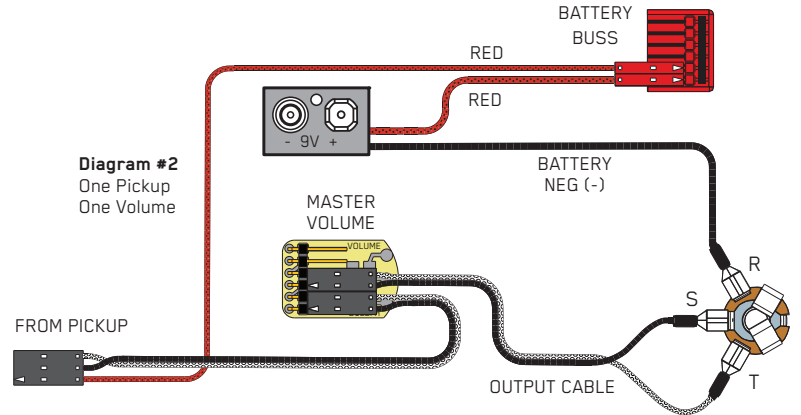

**Diagram #2**  
 One Pickup  
 One Volume

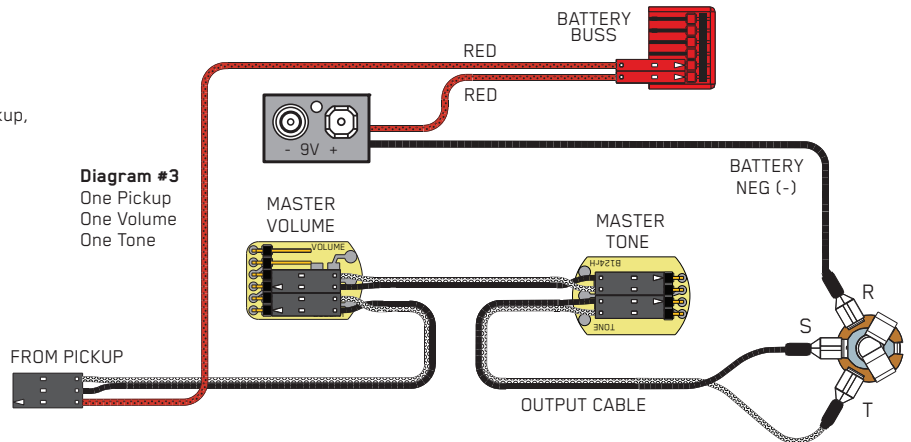

**Diagram #3**  
 One Pickup  
 One Volume  
 One Tone

**Using EMG Active Accessories (BTS, BQS, VLFP, etc.)**

Diagram #4 below shows the installation of a single volume control along with the BTS Control. This 5-pin layout is the same for all EMG Active Accessories, so they can be interchanged. Alternate wiring diagrams are available at: [emgpickups.com](http://emgpickups.com).

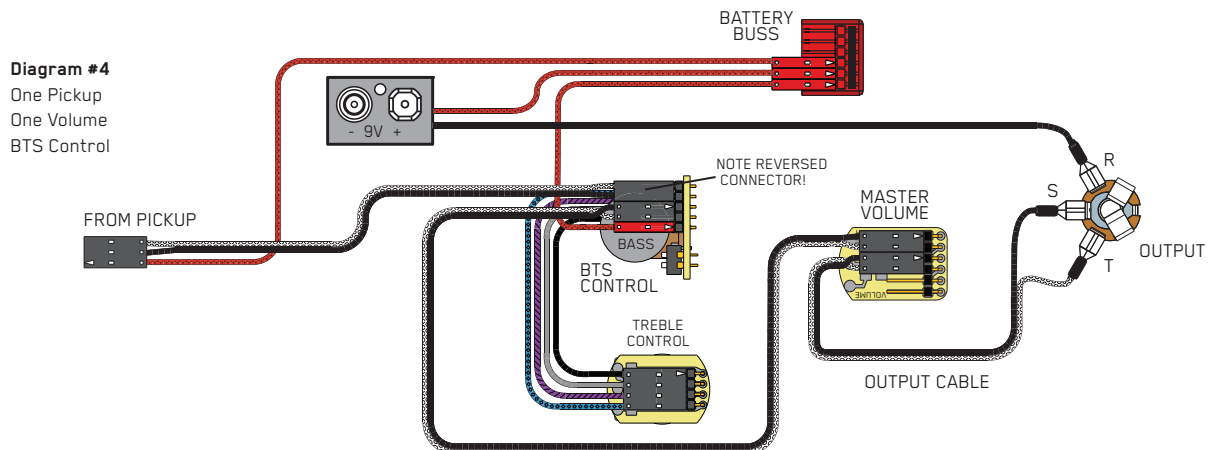

**Diagram #4**  
 One Pickup  
 One Volume  
 BTS Control

**Installation Instructions:**

**EMG Models: LC-PA**

**Installation (Two Pickup Bases):**

Refer to **Diagram #5** or **#6** for basses without a selection switch

Refer to **Diagram #7** for basses with a selector switch

- 1) Install the pickups and route the pickup cables to the control cavity. If the cables are too long, keep any excess under the pickup.
- 2) Mount the volume and tone controls into the body / pickguard.
- 3) Plug connector cables between the volume and tone controls as depicted for your specific bass, including the solderless output cable.
- 4) For switchless basses, go to step 5. For basses with a selector switch: Strip the insulation from the switch wires, insert them into the GREEN terminal block and tighten the screws with a small screwdriver. The Bridge pickup goes to the "BR" terminal, the Neck pickup goes to the "NK" terminal, and the Output of the switch goes to the "O" terminal. If there is a ground wire coming from the switch, connect it to a black "GND" terminal.
- 5) Connect the output cable to the jack by pushing the connectors on as shown. WHITE wire onto the TIP (T) contact, BLACK wire onto the SLEEVE (S) contact, BLACK battery negative wire onto the RING (R) contact.
- 5) Plug the RED Wires of the pickups onto the V+ Supply Buss (RED Shroud) along with the RED of the battery clip. Extra pins on the V+ Supply Buss are for EMG Accessories.
- 6) Wrap the battery in a piece of insulating foam and place it securely in the control cavity.

We suggest that you plug in the instrument and test it before closing the control cavity.

**\*\*\*\*Tips and Tricks\*\*\*\* Start your installation by:**

- 1) Determine which type output jack your instrument has. A Stereo 12B type is Included, but if you have a long panel jack a SwitchCraft 152B Long Panel Jack will be required.
- 2) Remove the strings, remove any existing pickups and controls (remember the order and function of each control)
- 3) Determine a good spot for the pickup buss and make sure the cable or wires from the selection switch will reach the pickup buss,
- 4) Install the EMG Volume and Tone Controls and tighten them in.
- 5) Then install the pickups keeping any excess cable under the pickup rather than in the control cavity.
- 6) **IMPORTANT: EMG Active Pickups do not require a string ground wire! DO NOT reconnect the string ground, it is unnecessary.**

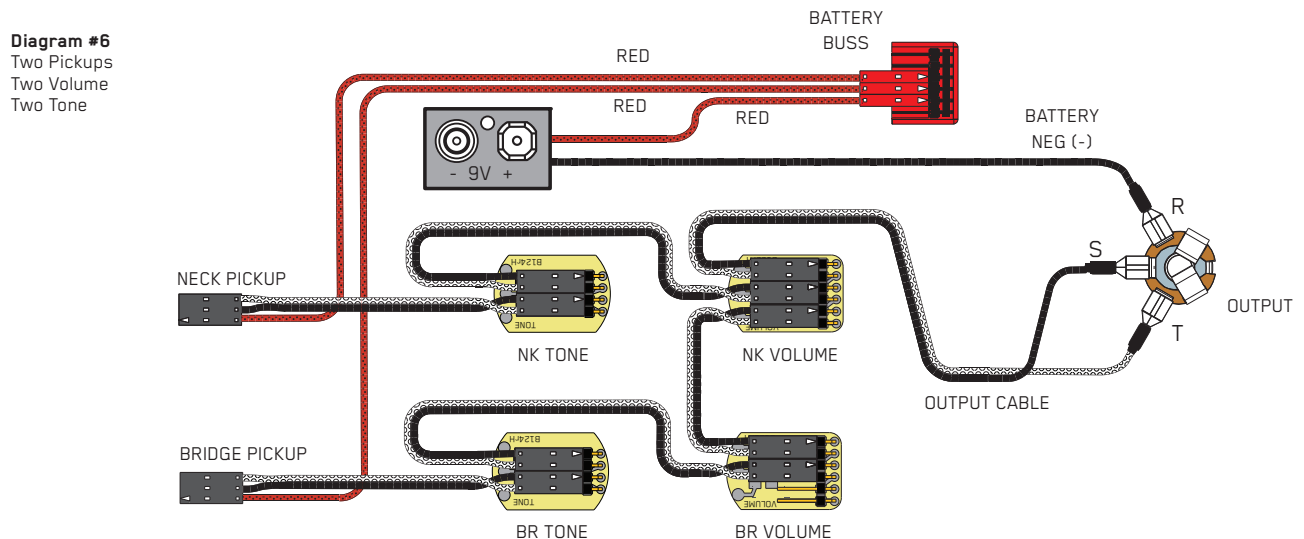
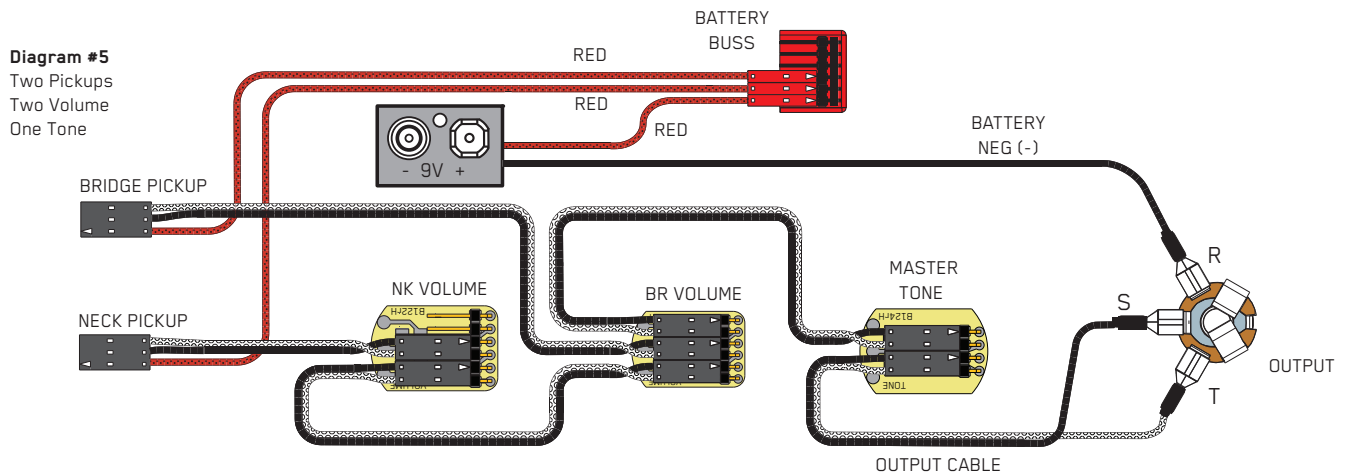

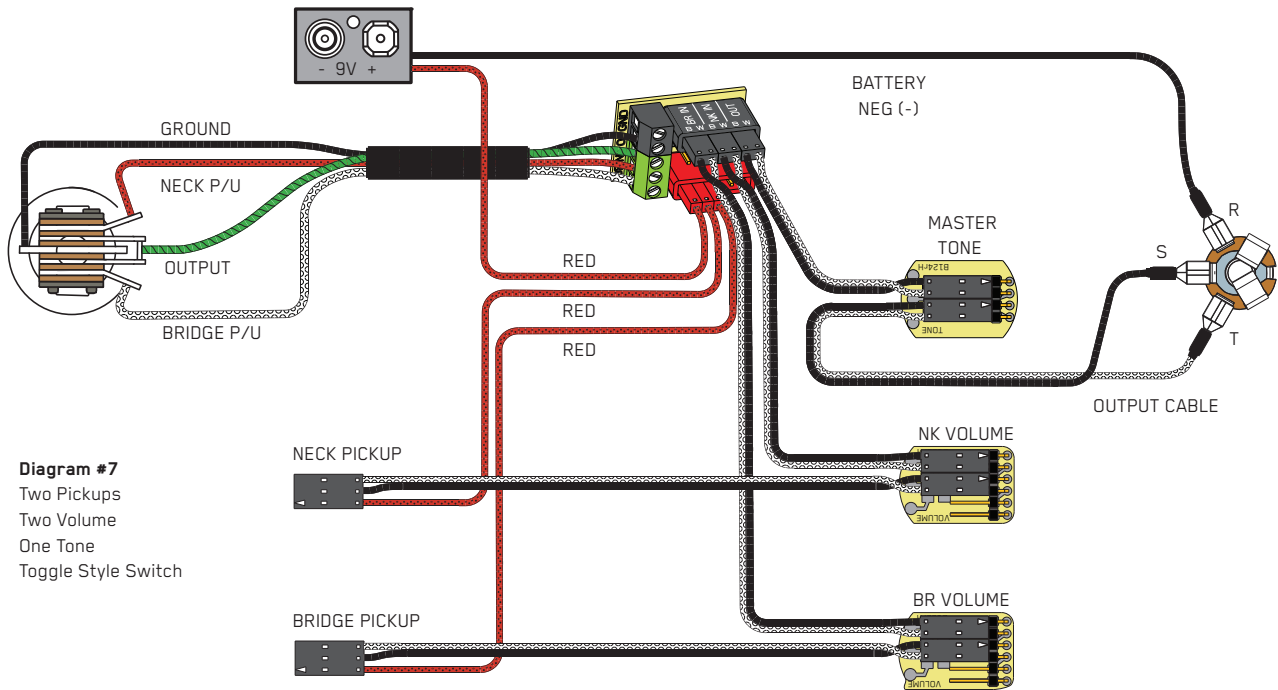

**Diagram #7**  
 Two Pickups  
 Two Volume  
 One Tone  
 Toggle Style Switch

**Diagram #8**

**Soldering to the 152B Panel Jack:**

If your instrument has a long panel jack like the one below you will have to solder the output cable as shown.

- Ground (Black) to the sleeve
- Signal (White) to the Tip
- Battery Negative (Black) to the Ring

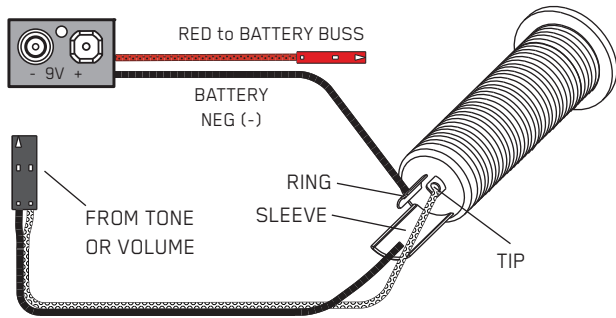

**Diagram #9**

**Installation with Mounting Standoffs:**

The included mounting standoffs may assist in the pickup installation process for certain instruments. The standoffs slip onto the long adjustment screws prior to mounting the pickups. This prevents the screws from being driven too deeply into the instrument. The standoffs are **not** intended for use with the short adjustment screws.

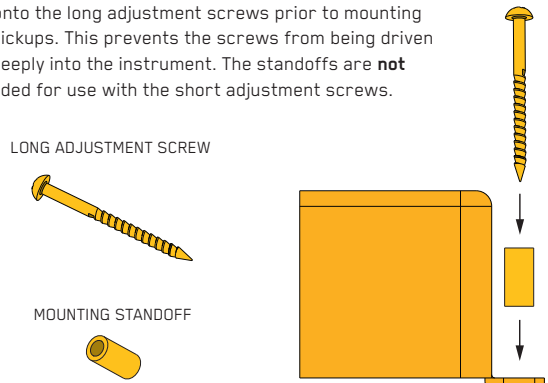

**Diagram #10**

**If the instrument has a Battery Holder:**

If your instrument has a 9 or 18 Volt battery holder you can still use the EMG Connectors to supply power to the pickups. Simply cut and strip the wires from the battery clip provided. Twist the wires together (Red to Red and Black to Black) and use the shrink tubing included to cover the connections. Soldering the wires is recommended.

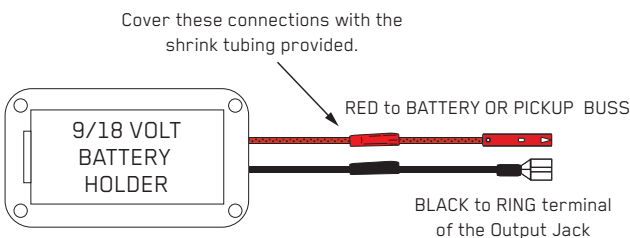

**Diagram #11**

**+18 Volt Wiring Option:**

If you want to operate your instrument at +18 Volts for more headroom then use 2 batteries wired as below. Also, if you are using any type of EQ in your instrument (EMG-BT, BQ) or anything that boosts the pickup signal then +18 Volts is recommended.

